

SOLAR SUPPORT SYSTEM IS NOT RATED FOR IMPACT.

SOLAR SUPPORT SYSTEM IS SECURED TO ROOF STRUCTURE (BY OTHERS)

QUICKMOUNT QBASE MOUNT & L-MOUNT SOLAR ROOF ATTACHMENTS

THIS PRODUCT HAS BEEN DESIGNED AND TESTED TO COMPLY WITH THE REQUIREMENTS OF THE 2017 (6TH EDITION) /2020 (7TH EDITION) FLORIDA BUILDING CODE NOT INCLUDING HIGH VELOCITY HURRICANE ZONE (HVHZ).

ANCHORS SHALL BE CORROSION RESISTANT, SPACED AS SHOWN ON DETAILS AND INSTALLED PER MANUF'S INSTRUCTIONS. SPECIFIED EMBEDMENT TO BASE MATERIAL SHALL BE BEYOND ROOF SHEATHING.

A LOAD DURATION INCREASE IS USED IN DESIGN OF ANCHORS INTO WOOD ONLY.

ALL SHIMS TO BE HIGH IMPACT, NON-METALLIC AND NON-COMPRESSIBLE.

MATERIALS INCLUDING BUT NOT LIMITED TO STEEL/METAL SCREWS, THAT COME INTO CONTACT WITH OTHER DISSIMILAR MATERIALS SHALL MEET THE REQUIREMENTS OF THE 2017/2020 FLORIDA BLDG. CODE & ADOPTED STANDARDS.

THIS PRODUCT APPROVAL IS GENERIC AND DOES NOT PROVIDE INFORMATION FOR A SITE SPECIFIC PROJECT, i.e. LIFE SAFETY OF THIS PRODUCT, ADEQUACY OF STRUCTURE RECEIVING THIS PRODUCT AND WEATHER SEALING FOR WATER INFILTRATION RESISTANCE ETC.

CONDITIONS NOT SHOWN IN THIS DRAWING ARE TO BE ANALYZED SEPARATELY, AND TO BE REVIEWED BY BUILDING OFFICIAL.

MANUFACTURER'S LABEL SHALL BE LOCATED ON A READILY VISIBLE LOCATION IN ACCORDANCE WITH SECTION 1703.5 OF FLORIDA BUILDING CODE. LABELING TO COMPLY WITH SECTION 1703.5.

DESIGN LOADS SHOWN ARE BASED ON 'ALLOWABLE STRESS DESIGN (ASD)'.

A- CONTRACTOR TO BE RESPONSIBLE FOR THE SELECTION, PURCHASE AND INSTALLATION OF THIS PRODUCT BASED ON THIS PRODUCT EVALUATION PROVIDED HE/SHE DOES NOT DEVIATE FROM THE CONDITIONS DETAILED ON THIS DOCUMENT.
B- THIS PRODUCT EVALUATION DOCUMENT WILL BE CONSIDERED INVALID IF ALTERED BY ANY MEANS.
C- SITE SPECIFIC PROJECTS SHALL BE PREPARED BY A FLORIDA REGISTERED ENGINEER OR ARCHITECT WHICH WILL BECOME THE ENGINEER OF RECORD (E.O.R.) FOR THE PROJECT AND WHO WILL BE RESPONSIBLE FOR THE PROPER USE OF THE P.E.D. ENGINEER OF RECORD, ACTING AS A DELEGATED ENGINEER TO THE P.E.D. ENGINEER SHALL SUBMIT TO THIS LATTER THE SITE SPECIFIC DRAWINGS FOR REVIEW.
D- THIS P.E.D. SHALL BEAR THE DATE AND ORIGINAL SEAL AND SIGNATURE OF THE PROFESSIONAL ENGINEER OF RECORD THAT PREPARED IT.

Sealed: 10/16/2020 FL #29846

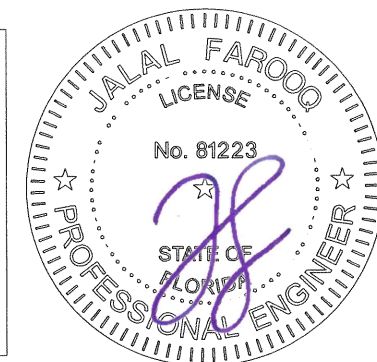

afc

AL-FAROOQ CORPORATION
ENGINEERS & PRODUCT DEVELOPMENT
9360 SUNSET DRIVE, SUITE 220
MIAMI, FLORIDA 33173 (C.A.N. 3538)
TEL. (305) 264-8100 FAX. (305) 262-6978
SOLAR-ROOF-ATTCHM\20-79

QBASE MOUNT & L-MOUNT SOLAR ROOF ATTACHMENTS (N.I.)
QUICKMOUNT
28357 Industrial Blvd.
Hayward, CA. 94545
Phone: (800) 227-9523 Fax: (510) 259-9747

revisions:	no	date	by	description

date: 10-09-20
scale: 1/2"=1'-0"
dr. by: MLS
chk. by:

drawing no.
20-79

sheet 1 of 4

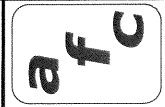

AL-FAROOQ CORPORATION
 ENGINEERS & PRODUCT DEVELOPMENT
 9360 SUNSET DRIVE, SUITE 220
 MIAMI, FLORIDA 33173 (C.A.N. 3538)
 TEL. (305) 264-8100 FAX. (305) 262-6978

QBASE MOUNT & L-MOUNT SOLAR ROOF ATTACHMENTS (N.I.)

QUICKMOUNT
 28357 Industrial Blvd.
 Hayward, CA. 94545
 Phone: (800) 227-9523 Fax: (510) 259-9747

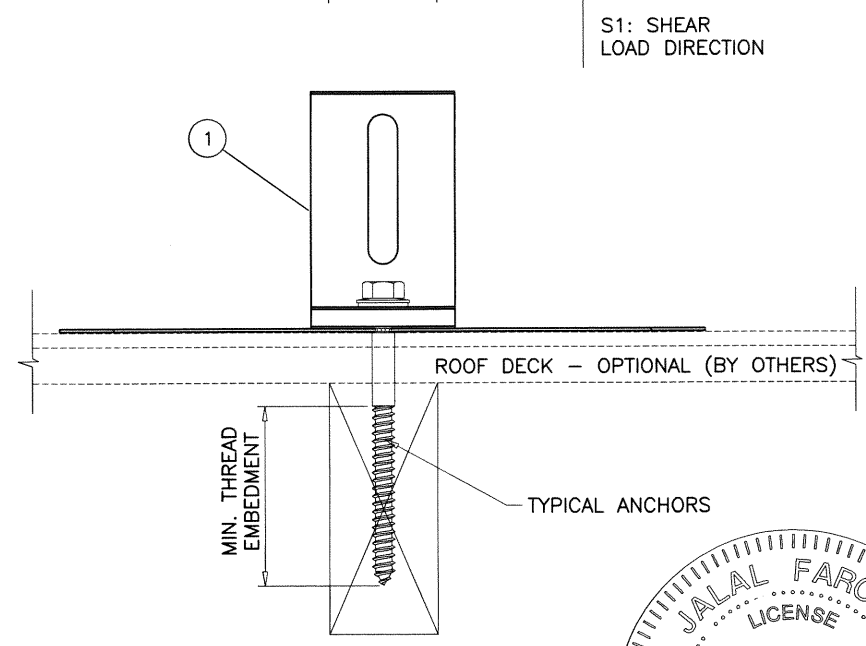
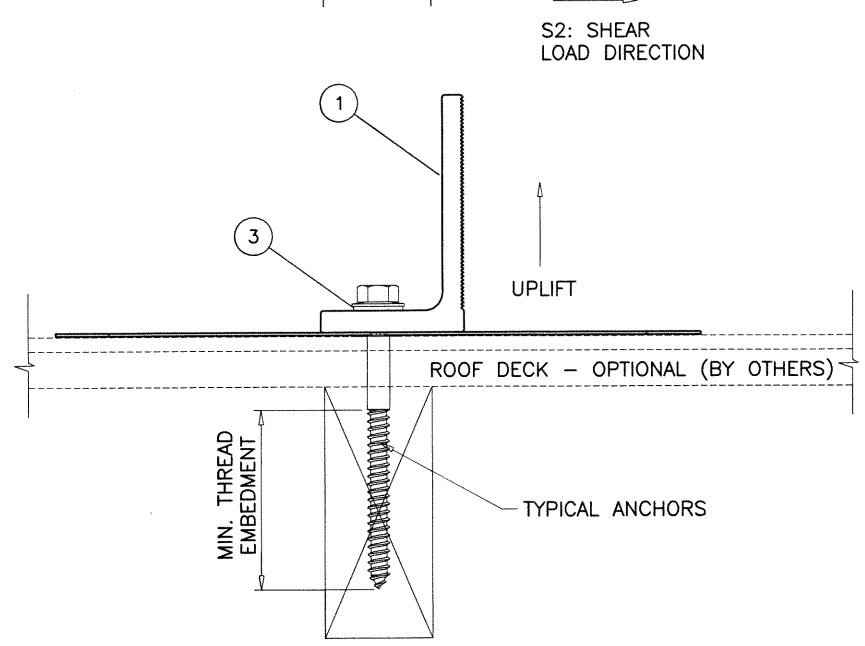
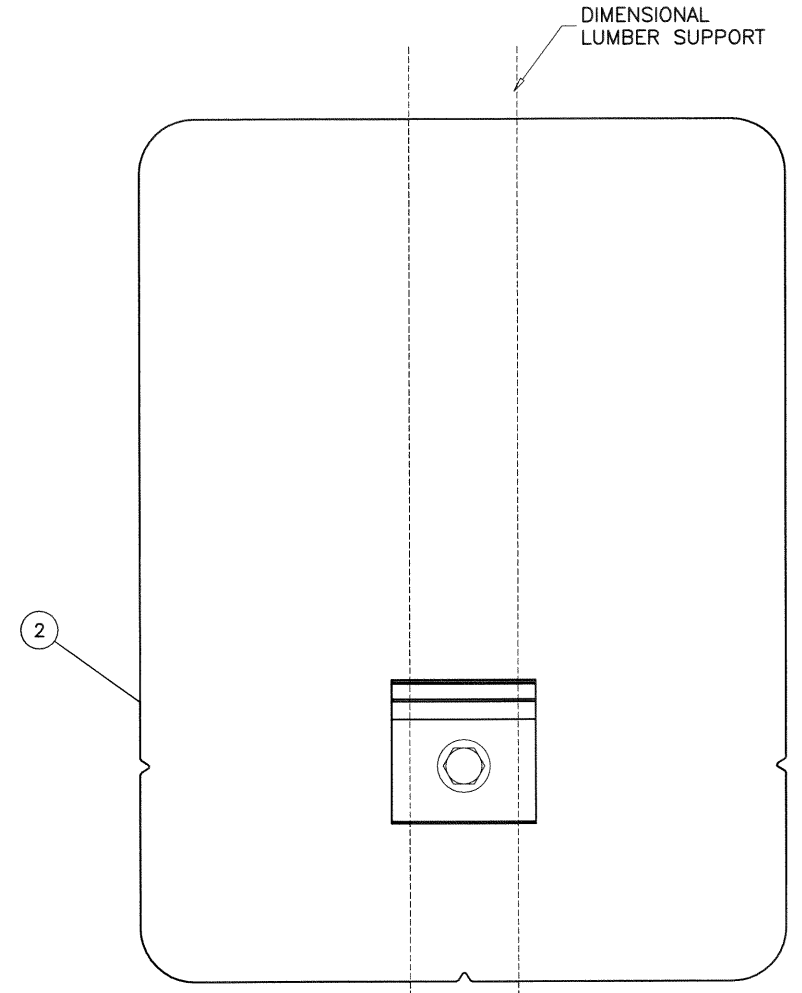
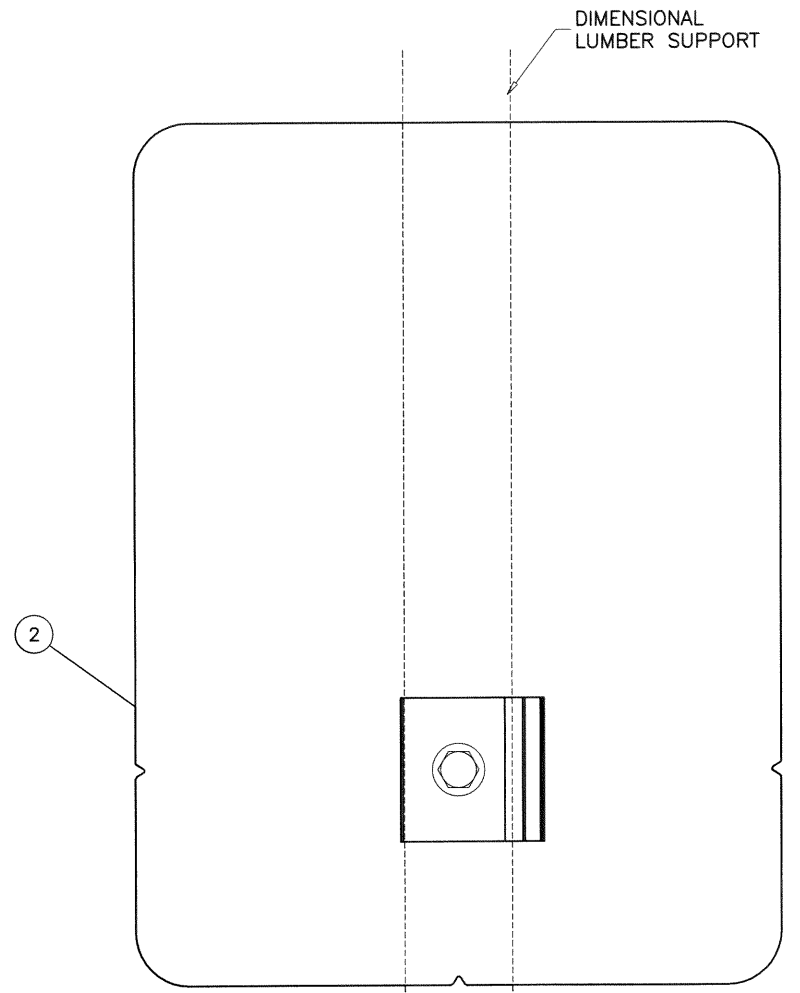

ROOF STRUCTURE AND ROOF DECK NOT BY QUICKMOUNT MUST SUSTAIN LOADS IMPOSED BY SOLAR SUPPORT SYSTEM AND TRANSFER THEM TO THE BUILDING STRUCTURE.

TYPICAL ANCHOR

TYPE 'A'- 5/16" DIA. X 4" HEX HEAD LAG SCREW. (Fy=60 KSI)
 INTO WOOD STRUCTURES
 2-5/16" MIN. THREAD PENETRATION INTO WOOD

CRITICAL EDGE DISTANCE

INTO WOOD STRUCTURE = 3/4" MIN.

WOOD SUBSTRUCTURE SG = 0.45 MIN.

MAXIMUM L-MOUNT SYSTEM WIND UPLIFT RESISTANCE = 1,437.5 LBS
 MAXIMUM L-MOUNT SYSTEM WIND SHEAR RESISTANCE S1 = 800 LBS
 MAXIMUM L-MOUNT SYSTEM WIND SHEAR RESISTANCE S2 = 1,025 LBS

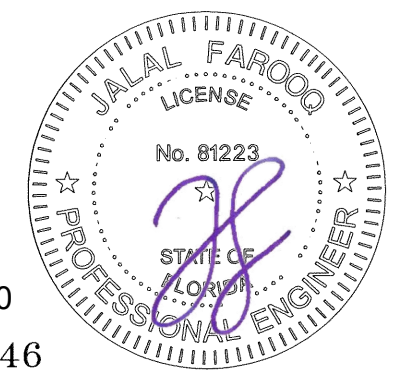

Sealed: 10/16/2020

FL #29846

revisions:	no	date	description

date: 10-09-20
 scale: 3/8"=1'-0"
 dr. by: MLS
 chk. by:

drawing no.
20-79

sheet 2 of 4



AL-FAROOQ CORPORATION
 ENGINEERS & PRODUCT DEVELOPMENT
 9360 SUNSET DRIVE, SUITE 220
 MIAMI, FLORIDA 33173 (C.A.N. 3538)
 TEL. (305) 264-8100 FAX. (305) 262-6978

SOLAR-SUPPORT 20-79

QBASE MOUNT & L-MOUNT SOLAR ROOF ATTACHMENTS (N.I.)

QUICKMOUNT
 28357 Industrial Blvd.
 Hayward, CA. 94545
 Phone: (800) 227-9523 Fax: (510) 259-9747

revisions:	no	date	description

date: 10-09-20
 scale: 3/8"=1'-0"
 dr. by: MLS
 chk. by:

drawing no.
20-79
 sheet 3 of 4

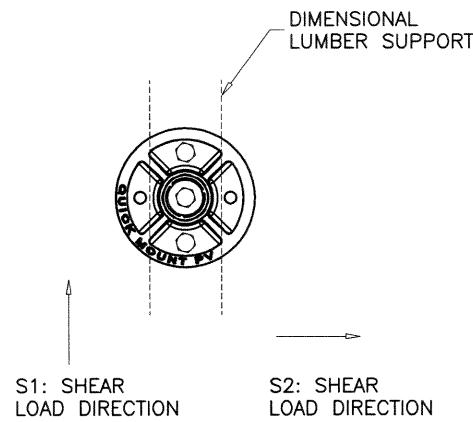
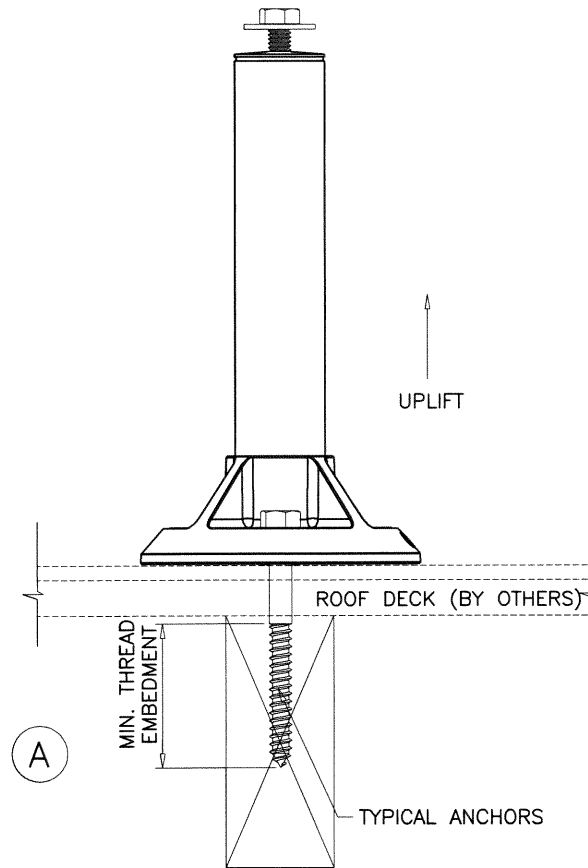
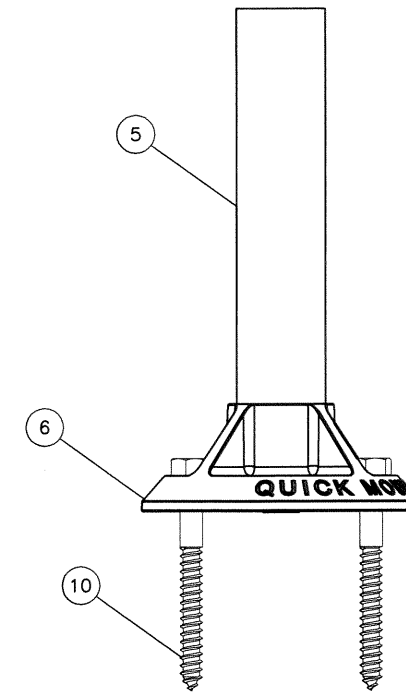
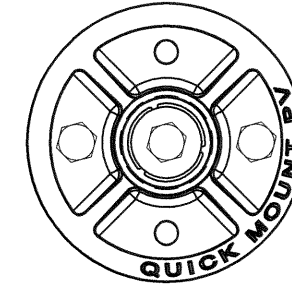

ROOF STRUCTURE AND ROOF DECK NOT BY QUICKMOUNT
 MUST SUSTAIN LOADS IMPOSED BY SOLAR SUPPORT SYSTEM
 AND TRANSFER THEM TO THE BUILDING STRUCTURE.

TYPICAL ANCHOR

TYPE 'A'- 5/16" DIA. X 3" HEX HEAD LAG SCREW. (Fy=60 KSI)
 INTO WOOD STRUCTURES
 1-13/16" MIN. THREAD PENETRATION INTO WOOD

CRITICAL EDGE DISTANCE

INTO WOOD STRUCTURE = 3/4" MIN.
 WOOD SUBSTRUCTURE SG = 0.45 MIN.

MAXIMUM Q-BASE SYSTEM WIND UPLIFT RESISTANCE = 1,212.5 LBS
 MAXIMUM Q-BASE SYSTEM WIND SHEAR RESISTANCE S1 = 687.5 LBS
 MAXIMUM Q-BASE SYSTEM WIND SHEAR RESISTANCE S2 = 950 LBS

Sealed: 10/16/2020

FL #29846

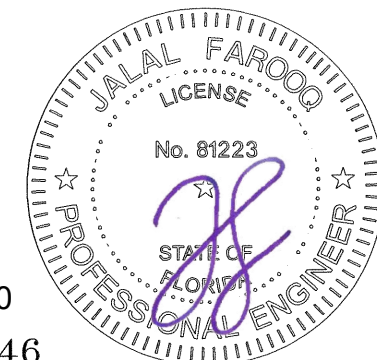

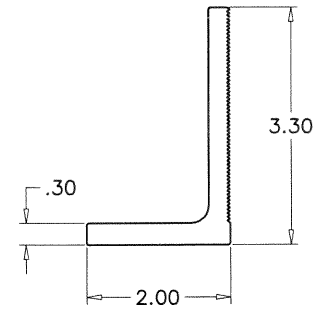

① L FOOT

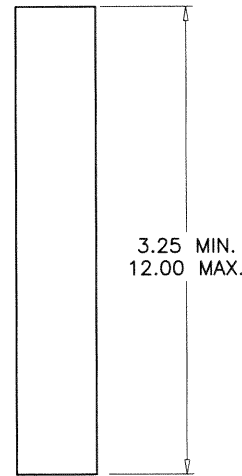

⑤ POST

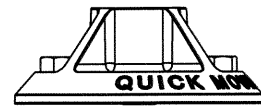

⑥ QBASE

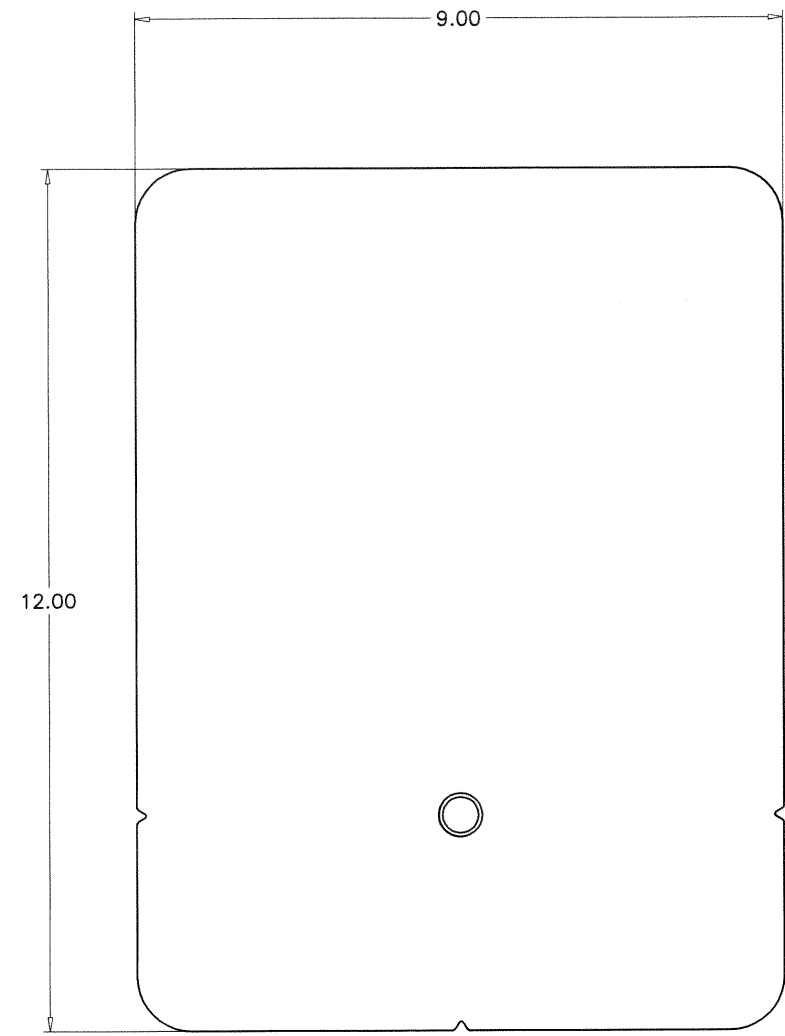

② FLASHING

L-MOUNT				
ITEM #	PART #	REQD.	DESCRIPTION	MATERIAL
1	--	AS REQD.	L-FOOT	6000 SERIES ALUM (Fy MIN. 35 KSI)
2	--	AS REQD.	9 " X 12" X 0.40" FLASHING	5000 SERIES ALUM
3	--	AS REQD.	5/16" ID X 3/4" OD. WASHER	EPDM BONDED S/S
4	--	AS REQD.	5/16" Ø X 4" HEX HEAD LAG SCREW	ZINC PLATED STEEL OR S/S

QBASE MOUNT				
ITEM #	PART #	REQD.	DESCRIPTION	MATERIAL
5	--	AS REQD.	1.25 Ø POST (3.25" MIN - 12.0" MAX.)	6000 SERIES ALUM (Fy MIN. 16 KSI)
6	--	AS REQD.	QBASE	300 SERIES ALUM (Fy MIN. 23 KSI)
7	--	AS REQD.	5/16"-18 X 3/4" CAP SCREW, H.H.	GRADE 8 MAGNI COATED
8	--	AS REQD.	5/16" ID X 1-1/4" OD. WASHER	EPDM BONDED SS
9	--	AS REQD.	5/16"-18 X 1" CAP SCREW H.H.	S/S
10	--	AS REQD.	5/16" Ø X 3" HEX HEAD LAG SCREW	ZINC PLATED STEEL OR S/S

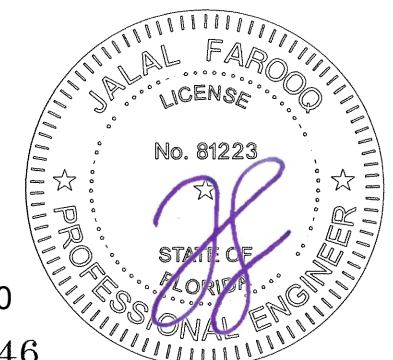
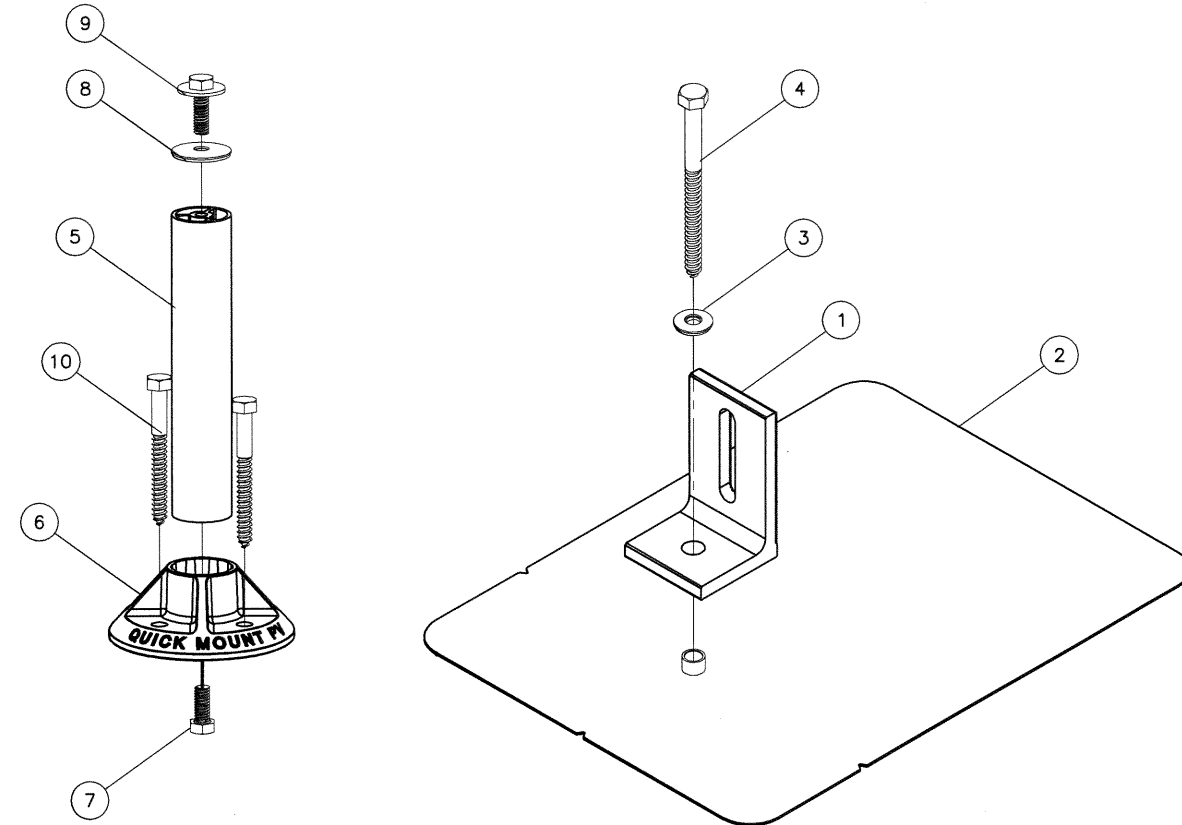

Sealed: 10/16/2020
FL #29846

af c
AL-FAROOQ CORPORATION
 ENGINEERS & PRODUCT DEVELOPMENT
 9360 SUNSET DRIVE, SUITE 220
 MIAMI, FLORIDA 33173 (C.A.N. 3538)
 TEL. (305) 264-8100 FAX. (305) 262-6978
 SOLAR-SUPPORT\20-79

QBASE MOUNT & L-MOUNT SOLAR ROOF ATTACHMENTS (N.I.)
QUICKMOUNT
 28357 Industrial Blvd.
 Hayward, CA. 94545
 Phone: (800) 227-9523 Fax: (510) 259-9747

revisions:	no	date	by	description

date: 10-09-20
 scale: 3/8"=1'-0"
 dr. by: MLS
 chk. by:

drawing no.
20-79
 sheet 4 of 4